

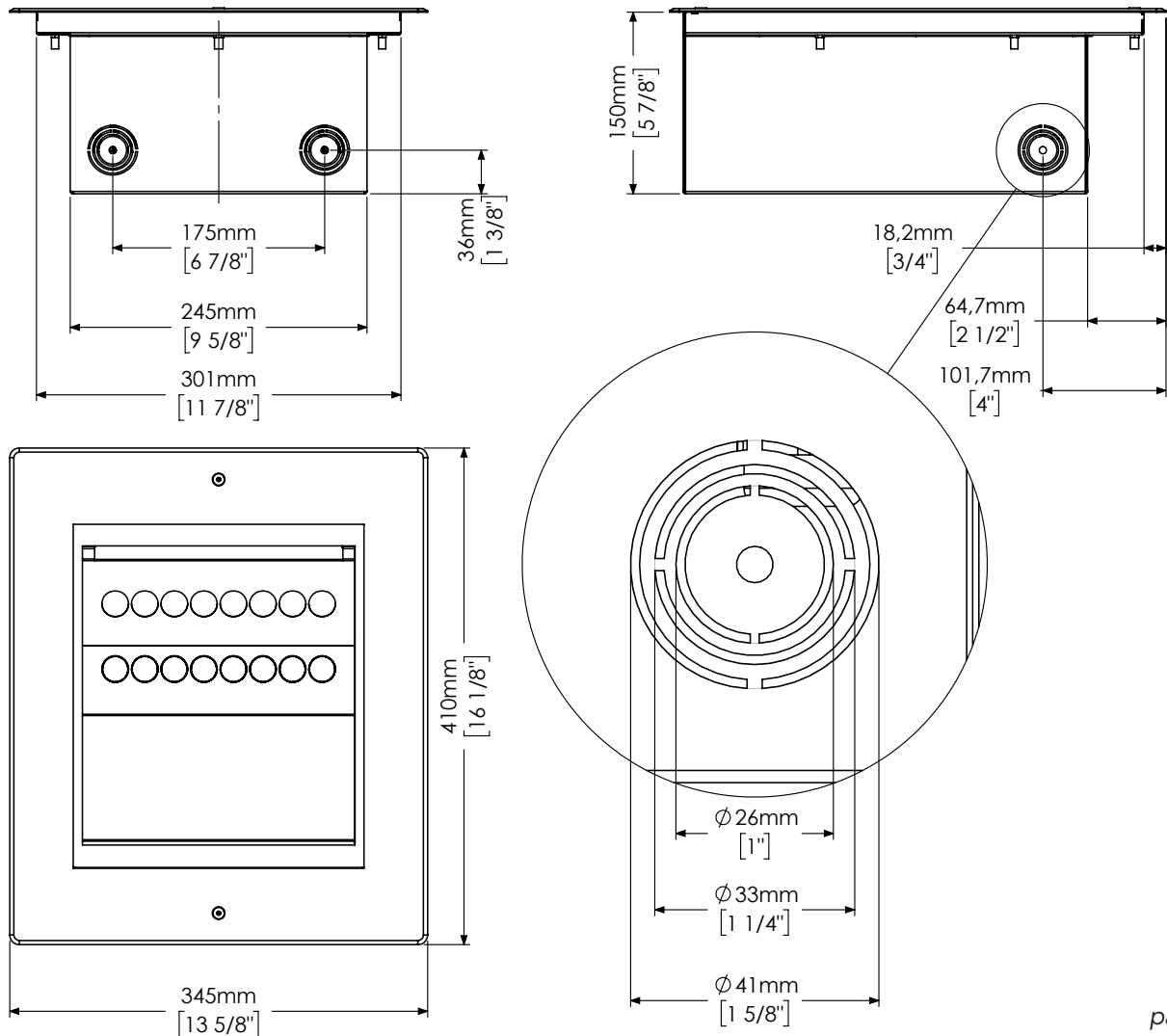

	GEA
Code / Codice	AL8410
Power consumption Consumo di energia	53 W
Nominal current Corrente nominale	0.24 A (CE)
Power supply Alimentazione elettrica	220-240VAC 50-60Hz (CE) 120 and 277VAC 50-60Hz (ETL)
Inrush current / Corrente di spunto	27.5 A@240VAC, cold start
Power factor / Fattore di potenza	cos.φ= 0.95
Electrical class / Classe elettrica	I / II
Weight / Peso	11 Kg (24.2 Lb)
Operating temperature Temperatura di funzionamento	-40°C to +50°C (-40°F to 122°F)
IP rating / Grado IP	IP67
IK rating / Grado IK	IK10

Dimensions / Dimensioni





Important notices - Avvisi importanti

- This product must be installed in accordance with applicable national and local electrical and construction codes by a person familiar with the construction and operation of the product and the hazards involved. Failure to comply with the following installation instructions may result in death or serious injury.
- Do not stare at the operating light source.
- The fixture might be damaged by excess voltage. The installation of an overvoltage protection device on the electrical system (SPD) is recommended for reduce the risk of damage.
- The use of an adequate magnetothermic switch along the power supply line is recommended.
- Connect the fixtures to each other only when disconnected from mains.
- Never leave cables and connectors unconnected or unprotected for long periods.
- Disconnect power before installing or servicing to avoid electrical shock.
- Disconnect power before any connection operation.
- Check voltage and frequency before powering the fixture. Do not exceed fixture specified voltage.
- Do not handle the unit with wet hands or in wet environments.
- Apply to qualified staff for any maintenance service not described in this instructions manual.
- Do not exceed the maximum quantity of fixtures per line in order to avoid power surges.
- Before powering the unit, ensure to use cables and connectors with proper section and length, according to its power consumption.
- Fix the projector by using screws, hooks or other adequate supports that can bear its weight.
- If the external flexible cable of this appliance is damaged, it must only be replaced by the manufacturer, its assistance service or equivalent qualified personnel in order to avoid hazards.
- The luminaire should be positioned so that prolonged observation of the luminaire at a distance of less than 2 meters (6.56 ft) is not expected.

- Questo prodotto deve essere installato secondo le normative locali, da personale specializzato. La mancata osservanza delle istruzioni di installazione può portare a situazioni di pericolo all'incolumità della persone.
- Non fissare la sorgente luminosa durante il suo funzionamento.
- Apparecchiatura sensibile alle sovratensioni. Si consiglia l'installazione di un dispositivo di protezione delle sovratensioni (SPD) sull'impianto elettrico per attenuare l'intensità di questi fenomeni proteggendo gli apparecchi dal rischio che vengano danneggiati.
- E' consigliato l'uso di un adeguato interruttore magnetotermico/differenziale sulla linea di alimentazione.
- Collegare tra loro i proiettori solo quando nessuno di essi è collegato alla rete elettrica.
- Non lasciare mai per lungo tempo agli agenti atmosferici cavi e connettori non collegati o non protetti.
- Togliere l'alimentazione prima di effettuare qualsiasi operazione all'interno dell'apparecchiatura.
- Togliere l'alimentazione prima di effettuare qualsiasi operazione di connessione tra gli apparecchi.
- Prima di connettere l'apparecchio alla rete elettrica, verificate la compatibilità di tensione e frequenza.
- Non maneggiate il prodotto con mani bagnate o in presenza di acqua.
- Rivolgersi ad un tecnico qualificato per qualsiasi operazione di manutenzione ordinaria non descritta nel presente manuale.
- Non superare il numero massimo specificato di apparecchi per linea per evitare pericolosi sovraccarichi di corrente.
- Prima di effettuare le connessioni verificare la portata dei cavi / connettori e la lunghezza dei cavi tenendo conto dell'assorbimento del prodotto.
- Fissare il proiettore con viti, ganci o altri supporti in grado di sostenerne il peso.
- Se il cavo flessibile esterno di questo apparecchio viene danneggiato, deve essere sostituito esclusivamente dal produttore, dal suo servizio di assistenza o da personale qualificato equivalente, al fine di evitare pericoli.
- l'apparecchio di illuminazione dovrebbe essere posizionato in modo che non sia prevista un'osservazione prolungata dell'apparecchio ad una distanza inferiore a 2 metri.

  **CAUTION:** Prolonged staring at the LED source should be avoided by placing the fixture in a proper position.

  **WARNING !** Fixing and connecting operations must mandatorily be carried out by qualified personnel only !

  **WARNING !** Make sure that power supply is off before connecting or disconnecting fixtures !



The possibility of reusing some electrical parts of the device is subject to the total responsibility of the user. The label shows the symbol indicated in Legislative Decree n.49 of 14 March 2014 which transposes Directive 2012/19 / EU, which indicates the need to dispose of the product in separate waste, specifically in electrical waste, and electronic. Refer to the waste collection center located in your area.





Replaceable control gear by a professional



Replaceable (LED only) light source by a professional

This product contains a light source of energy efficiency class:

  **ATTENZIONE!** Fissare la sorgente LED per un periodo prolungato va evitato posizionando l'apparecchio nella posizione appropriata.

  **ATTENZIONE !** Le operazioni di fissaggio e collegamento devono essere eseguite solo e obbligatoriamente da personale qualificato!

  **ATTENZIONE !** Assicurarsi che l'alimentazione sia spenta prima di collegare o scollegare i dispositivi!



La possibilità di riutilizzare alcune parti elettriche del dispositivo è subordinata alla totale responsabilità dell'utilizzatore. Nell'etichetta è stato riportato il simbolo indicato nel D.lgs n.49 del 14 Marzo 2014 che recepisce la direttiva 2012/19/UE, il quale indica la necessità di smaltire il prodotto nei rifiuti differenziati, nello specifico nei rifiuti di tipo elettrico ed elettronico. Fare riferimento al centro di raccolta rifiuti situato nella Vostra zona.



Alimentatore sostituibile da un professionista



Sorgente luminosa (solo LED) sostituibile da un professionista

Questo prodotto contiene una sorgente luminosa di classe di efficienza energetica:

Installation - Installazione

Install the formwork.
Installare la cassaforma.

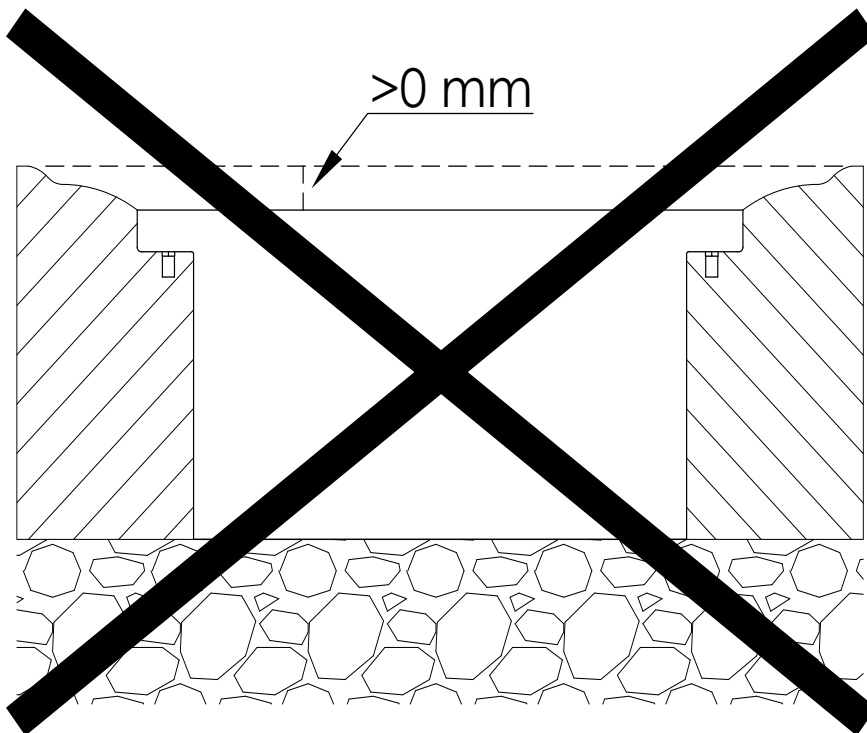
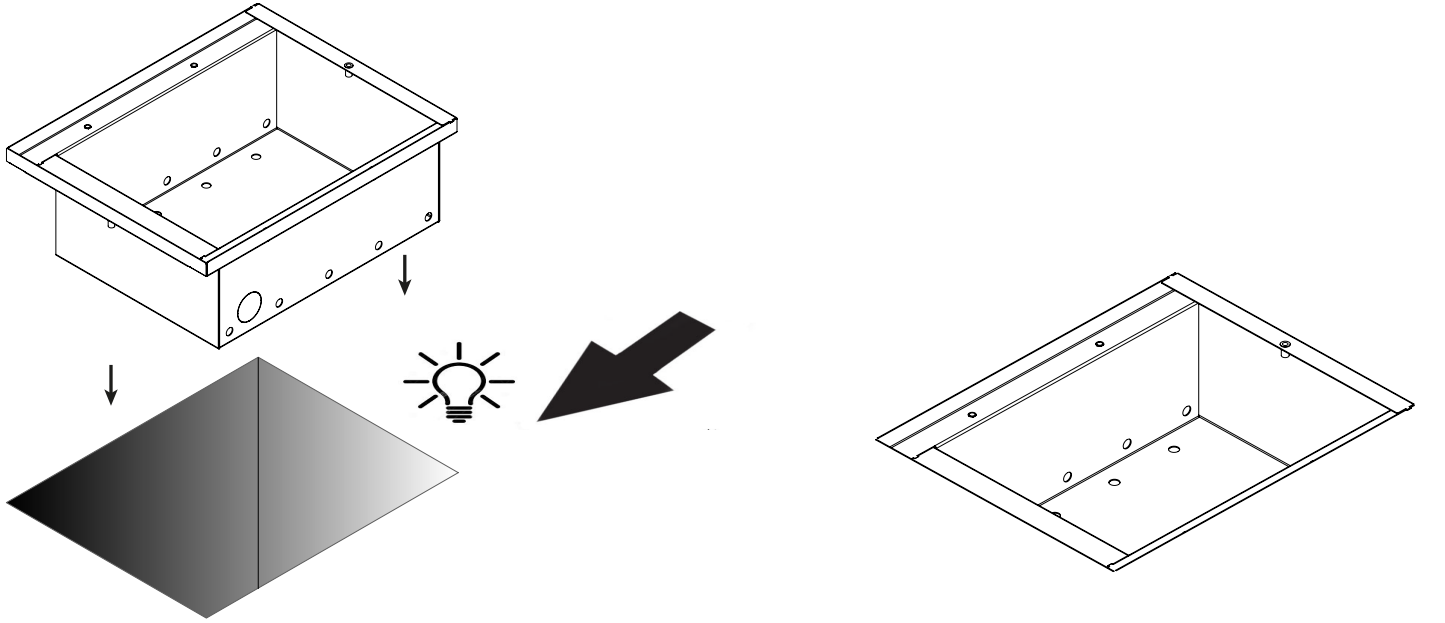

**Never install the formwork
below ground level !**

**Non installare la cassaforma al
di sotto del livello del suolo !**

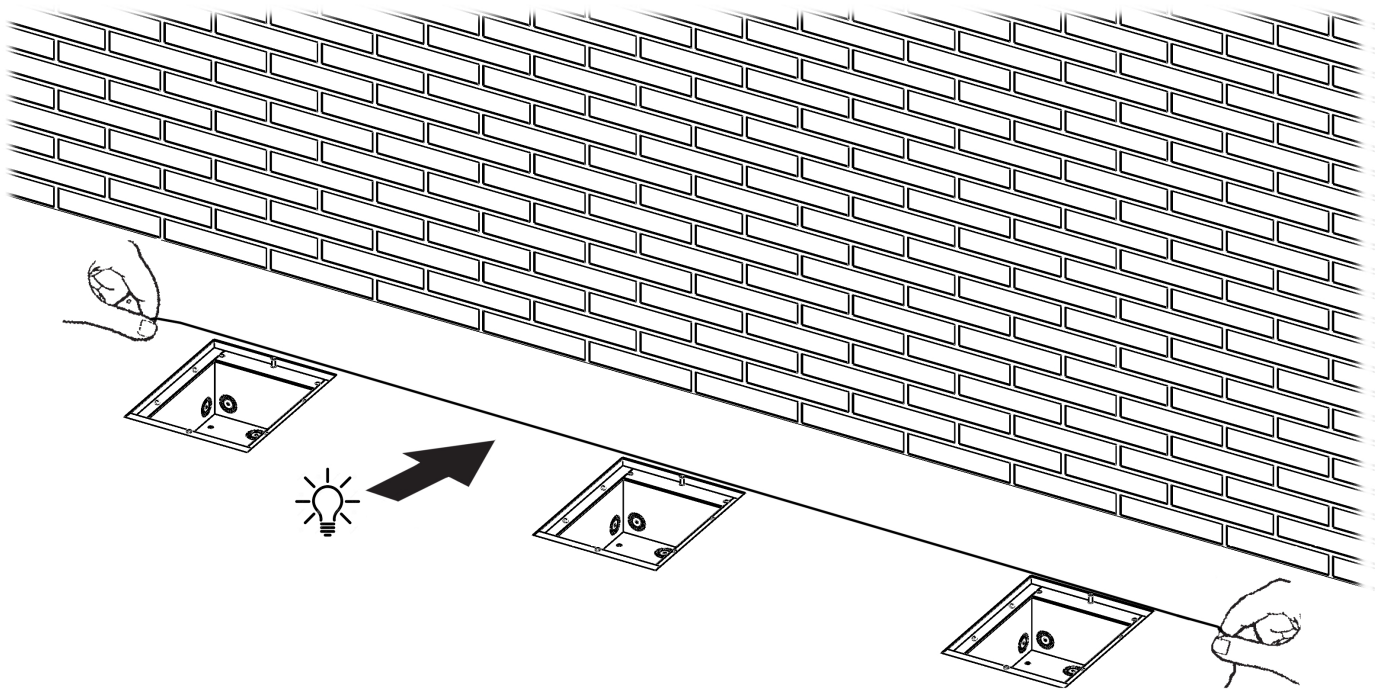

Screw the body into the formwork.
Avvitare il corpo nella cassaforma.

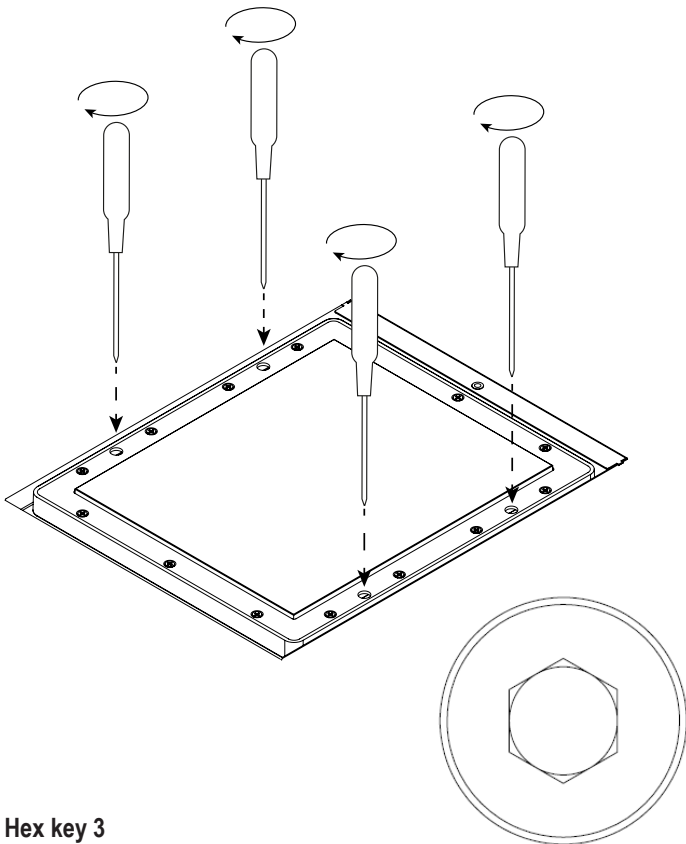

Hex key 3
Chiave esagonale 3

Screw the frame back on.
Riavvitare la cornice.

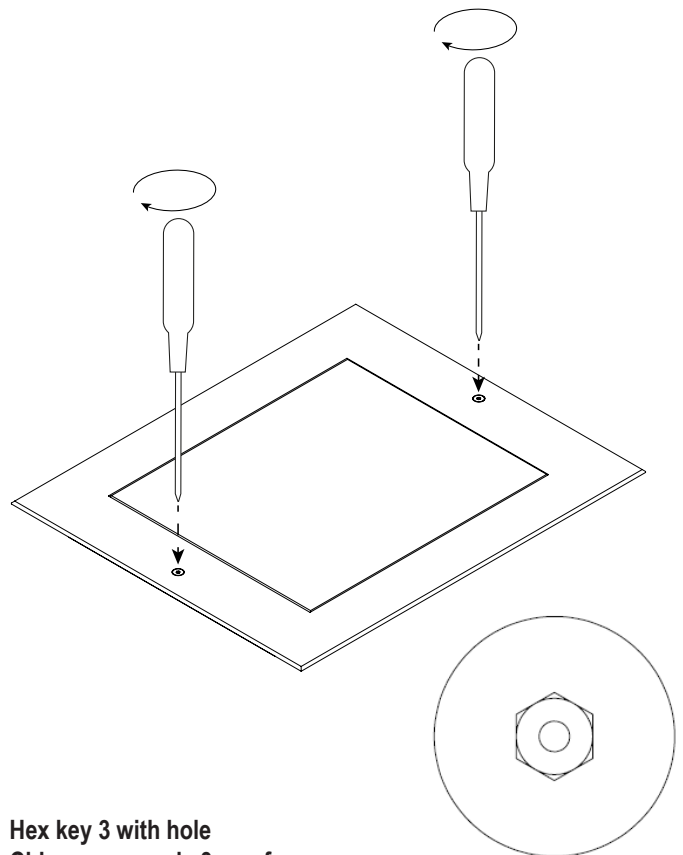

Hex key 3 with hole
Chiave esagonale 3 con foro

"4" type cable (Power in, Power Out, DMX In, DMX Out)
Cavo tipo "4" (Power in, Power Out, DMX In, DMX Out)

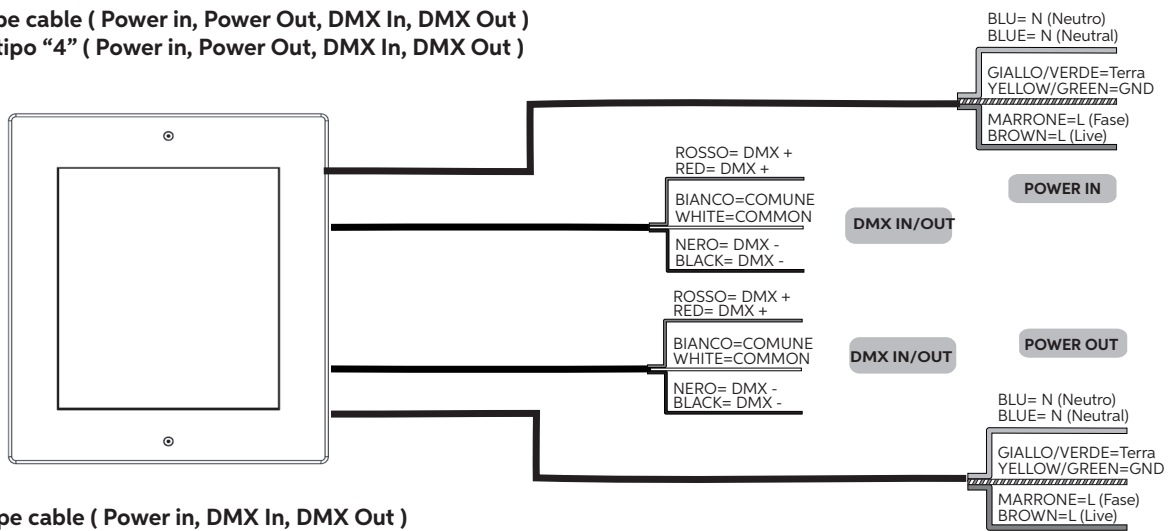

"S" type cable (Power in, DMX In, DMX Out)
Cavo tipo "S" (Power in, DMX In, DMX Out)

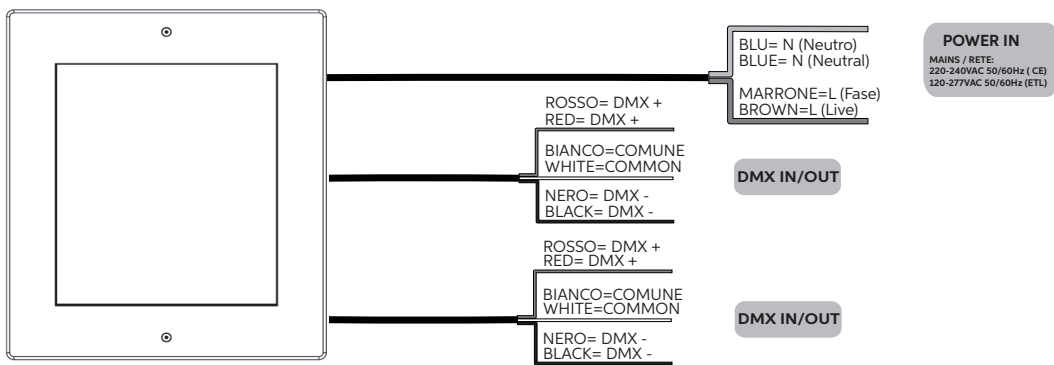

"C" type cable (Hybrid cable + connectors)
Cavo tipo "C" (Cavo ibrido + connettori)

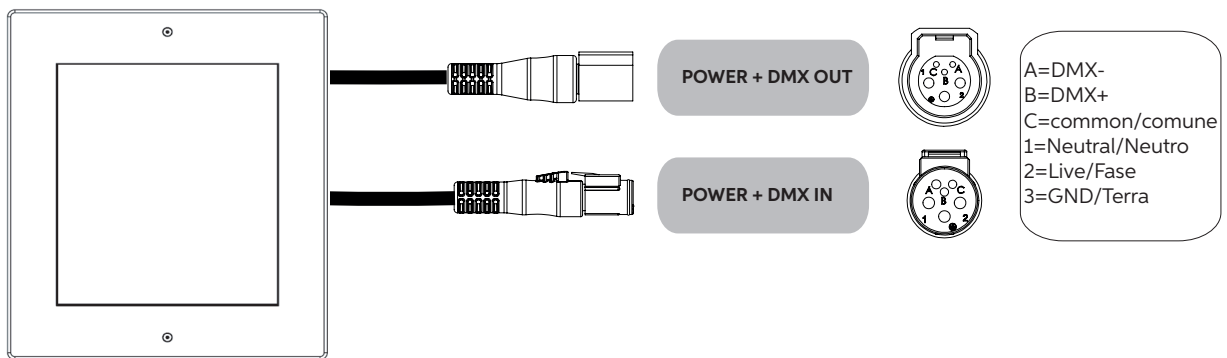

"M" type cable (Hybrid cable without connectors - DMX)
Cavo tipo "M" (Cavo ibrido senza connettori - DMX)

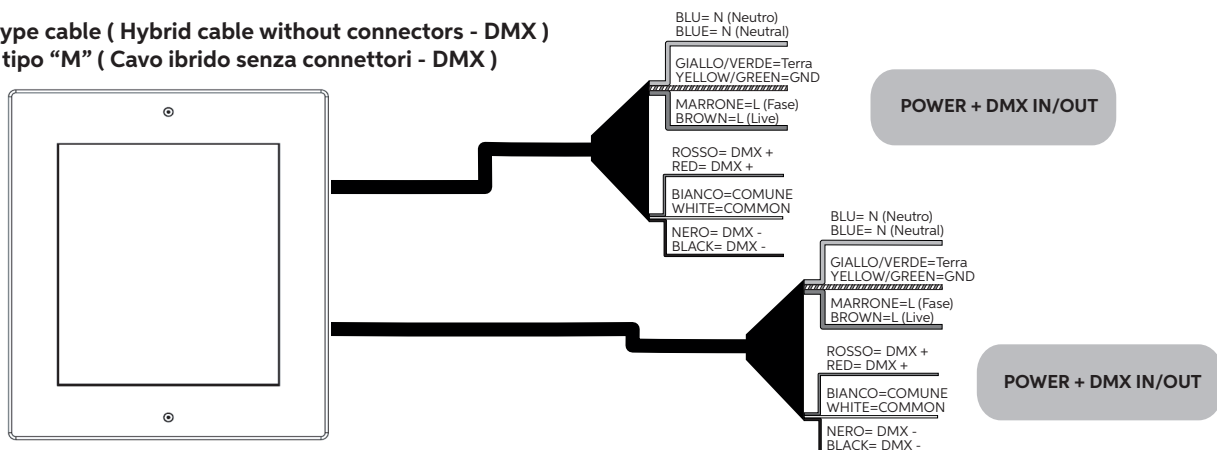

IR Remote Control operations / Operazioni del telecomando IR

The fixture must be configured only by using AL1321 IR remote control (sold separately) or via any DMX-RDM compatible controller.

L'apparecchiatura deve essere configurata solo utilizzando il telecomando IR AL1321 (venduto separatamente) o tramite qualsiasi controller compatibile DMX-RDM.

LOGIN		1 2 3	 5' inactivity = Automatic LOGOUT 5' inattività = Automatico LOGOUT	 = OK
DMX MODE	DMX MODE SETTING		Enter the corresponding "IR" value (see DMX chart Mode Column) to select the desired DMX Mode (e.g.: for IR=4press button 4). Immettere il valore "IR" corrispondente (vedi colonna DMX chart Mode) per selezionare la modalità DMX desiderata (es.: per IR=4 premere il pulsante 4).	 = OK
	DMX ADDRESS SETTING		001~512	 = OK
MASTER/SLAVE AUTOMATIC MODE TO BE USED ONLY WITH DMX MODE #1	AUTOMATIC/MASTER	 Green-Cyan-Blue-Magenta-Red-Yellow-White.	 	 5"→10"→20"→40" 40"→20"→10"→5"
	SLAVE FIXTURE SETTING		001	 = OK
FIXED COLOR MODE (RGB-RGBW-DW) TO BE USED ONLY WITH DMX MODE #1			RGB 1 = RED 2 = GREEN 3 = BLUE DW 5 = WARM WHITE 6 = COLD WHITE	 0%→100%
DIMMER MODE (Monochromatic) TO BE USED ONLY WITH DMX MODE #1			 100%→0% 	
LOGOUT	OK		1	
RESET	OK		7 8 9	Reset to default settings
WIRELESS			1 = Unlink 2= wireless LED status ON 3= wireless LED status OFF	
GEA W TO BE USED ONLY AFTER LOGIN			1-Spot 2-Wall Washer 3-Ultra White 	 0%→100% 100%→0%

¹ WARNING ! in this mode, no other DMX control device must be present along the line.

² Only on wireless fixtures

¹ ATTENZIONE ! in questa modalità non deve essere presente lungo la linea nessun altro dispositivo di controllo DMX.

² Solo su dispositivi wireless

DMX Chart

RGBW

Mode	Channel	Function	Value
#1 IR=4	1	0-100% Red	0-255
	2	0-100% Green	0-255
	3	0-100% Blue	0-255
	4	0-100% Calibrated White (affects RGB channels)	0-255

Note: in absence of DMX signal the LEDs will remain **OFF**.

DW

Mode	Channel	Function	Value
#1 IR=2 (Default)	1	0%-100% Warm white	0-255
	2	0%-100% Cold White	0-255

Note: in absence of DMX signal the LEDs will remain **ON**.

Monochromatic version

Channel	Function	Value
1	0%-100% dimmer	0-255

Note: in absence of DMX signal the LEDs will remain **ON**.

RDM functions

When operating in DMX mode the fixture can accept the following RDM commands:

- Discovery: upon request of the RDM controller, the fixture will signal its own presence (the RDM controller will display the fixture on a list).
- DMX address reading and setting.
- Channels number reading and setting.
- On / Off identification: this command is used to identify the fixture you want to get access to (the identification happens by switching on all the LEDs at full intensity).
- Manufacturer: it displays the name of the manufacturer (Griven).
- Model description: it displays the fixture's model.
- Software version description: it displays the current version of the firmware.
- Temperature: it displays the LEDs operating temperature value.

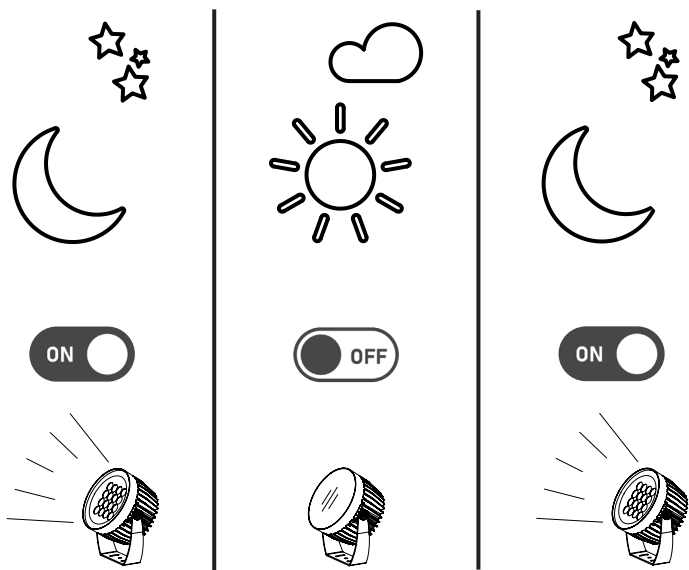

Nota: Accensione dell'apparecchio ammessa soltanto tra gli orari di tramonto e alba

Note: Allowed operation only between sunset and sunrise

Configuration examples / Esempi di configurazioni

DMX Chain configuration - 4 type cable

Configurazione DMX - Tipo di cavo 4

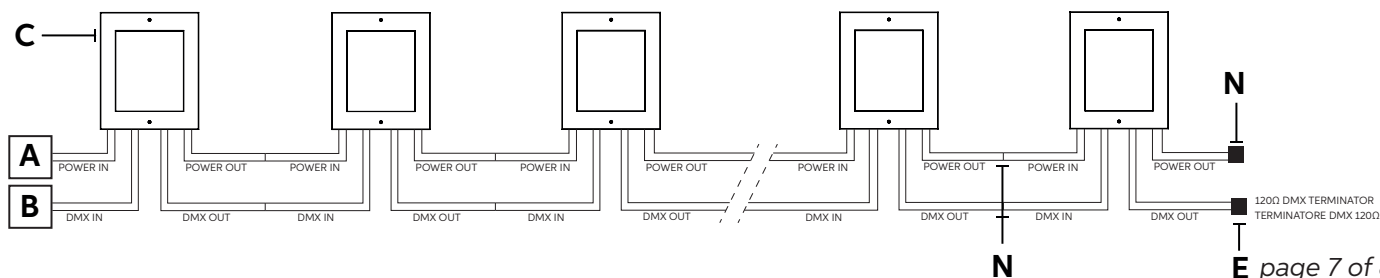

DMX Chain configuration - S type cable

Configurazione DMX - Tipo di cavo S

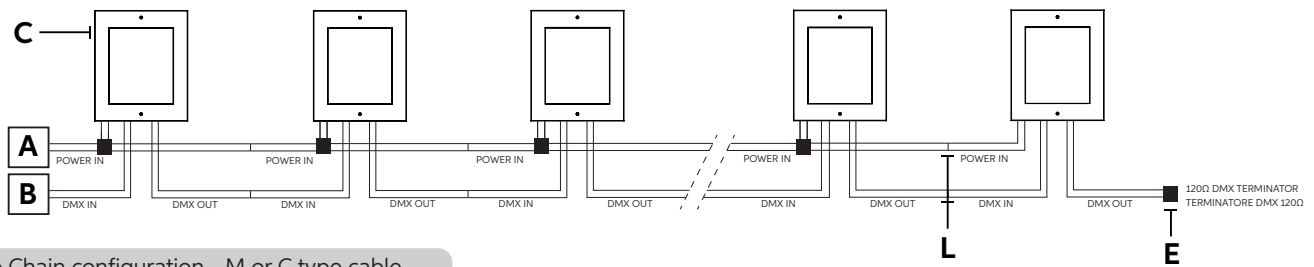

Single Chain configuration - M or C type cable

Configurazione catena singola - Tipo di cavo M o C

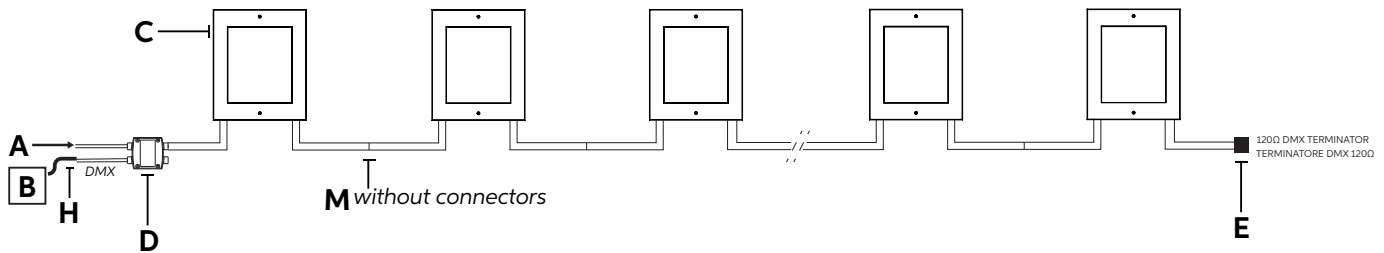

Multi Chain configuration using Repower Box - M or C type cable

Configurazione multi catena utilizzando una Repower Box - Tipo di cavo M o C

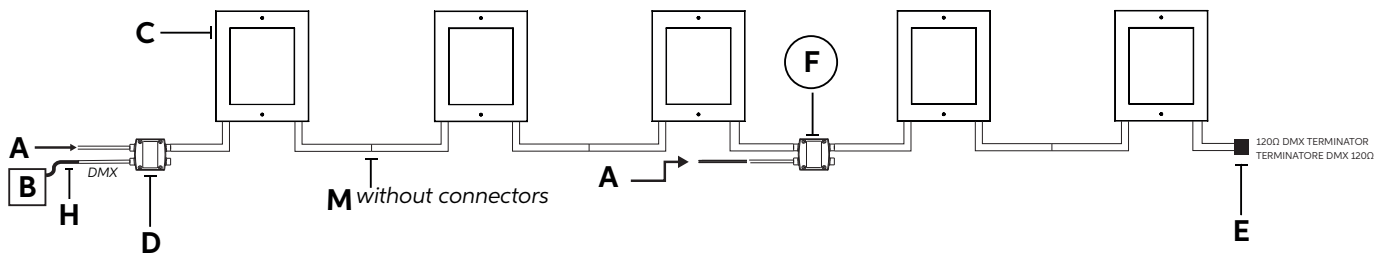

Multi Chain configuration using DMX junction Box - M or C type cable

Configurazione multi catena utilizzando una scatola di giunzione per DMX - Tipo di cavo M o C

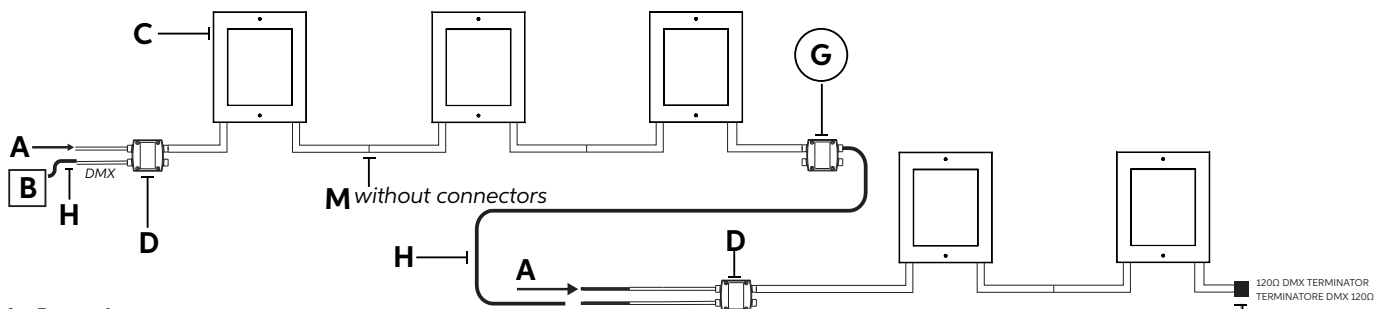

- A - Power Input
- B - DMX/RDM Controller
- C - GEA
- D - Start Line Box - AL5058C with connectors / AL5058M without connectors
- E - DMX Terminator - AL5169 (with connector) - AL4469 without connectors
- F - Repower Box - AL5167C with connectors / AL5167M without connectors
- G - DMX Junction Box - AL5059C with connectors / AL5059M without connectors
- H - DMX Cable - AL0512
- L - CONNECTION KIT Power in + DMX in/out - AL8284
- M - CONNECTION KIT Hybrid Cable - AL8287
- N - CONNECTOR KIT Power in/out + DMX in/out - AL8516

DMX cable type:

2x0.34 mm² impedance 110Ω, capacity 43pF/m, resistance 50Ω/Km.

Max. 10A

per daisy chain

Use a DMX repeater on each **32nd** fixture of the daisy chain or in case the total DMX LINE length exceeds 300m (1000 ft)

Tipo di cavo DMX:

2x0,34 mm² impedenza 110Ω, capacità 43pF / m, resistenza 50Ω / Km.

Max. 10A

per catena

Utilizzare un ripetitore DMX ogni **32** apparecchi della catena o se la lunghezza totale della LINEA DMX supera i 300 m (1000 piedi)